

Rettbox[®]

Rettbox[®]-air

The innovative power supply...



...with automatic
separating function

Power and compressed
air in one supply line

Rettbox[®]

Rettbox[®]-air



...for rescue and fire brigade vehicles



ISV Industrie Steck-Vorrichtungen GmbH

Rettbox® / Rettbox®-air

Get out faster...

Power

or

**Power and compressed air
in one supply line**

Rettbox® and Rettbox®-air offer an innovative solution for power and compressed air supplies to rescue and fire brigade vehicles.

The system comprises a glass-fibre reinforced polyamide housing with protective isolation and a sliding cover as well as a plug and socket device with butt contacts.

When the vehicle is started up, the supply line is separated from the vehicle automatically and within a split second. As soon as the driver activates the vehicle ignition, the magnet sends an impulse to the trigger hook of the socket. Pressure springs eject the coupler socket, with the sliding cover closing automatically at the same time.

With the Rettbox®-air version, the compressed air supply is integrated in the plug and socket and is thus separated simultaneously.

The vehicle can now drive away perfectly safely.

→ **Rettbox®** 

→ **Rettbox®-air**



Coupler socket made of glass-fibre reinforced polyester

Glass-fibre reinforced polyamide housing with protective isolation

Electric lifting magnet 12 / 24V for automatic separation when the engine is started



Rettbox®-air

Compressed air

Power and compressed air in one supply line

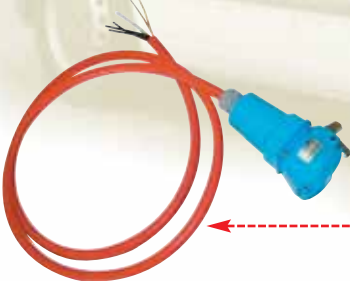



Technical description

Rettbox®

Loading box and coupler socket, prewired

- Power supply: 20A / 12V, 24V, 230V or 400V
- Electrical ejection mechanism (lifting magnet): 12V or 24V
- Contacts: Butt contacts with silver-nickel tips, 2 to 5 contacts
- Protection degree: IP55
- Loading box: glass-fibre reinforced polyamide with protective isolation
- Sliding cover and frame made of V4A stainless steel
- Pre-wired for easy installation

Rettbox®-air

Loading box, pre-wired, and coupler socket with supply line (power and compressed air in one cable)

- Power supply: 20A / 12V, 24V or 230V
- Electrical ejection mechanism (lifting magnet): 12V or 24V
- Contacts: Butt contacts with silver-nickel tips, 2 to 4 contacts
- Compressed air: 13 bar max.
- Protection degree: IP55
- Loading box: glass-fibre reinforced polyamide with protective isolation
- Sliding cover and frame made of V4A stainless steel
- Pre-wired for easy installation

Rettbox® now available up to 32A / 3P + N + E

Installation dimensions:

Rettbox®/Rettbox®-air:	83 x 163 x 94 mm (W x H x D)
Outer frame:	107 x 180 mm (W x H)
Height with lid slid out:	318 mm
Weight without coupler socket:	1200 g

...on a rescue mission



ISV Industrie Steck-Vorrichtungen GmbH

Im Lossenfeld 8 · D 77731 Willstätt-Sand (Germany)
 Tel.: +(49) (0) 78 52/9196 0 · Fax: +(49) (0) 78 52 /91 96 19
 www.isv.de / E-Mail: info@isv.de
 www.rettbox.de



Rettbox® / Rettbox-air®



Dimensions:

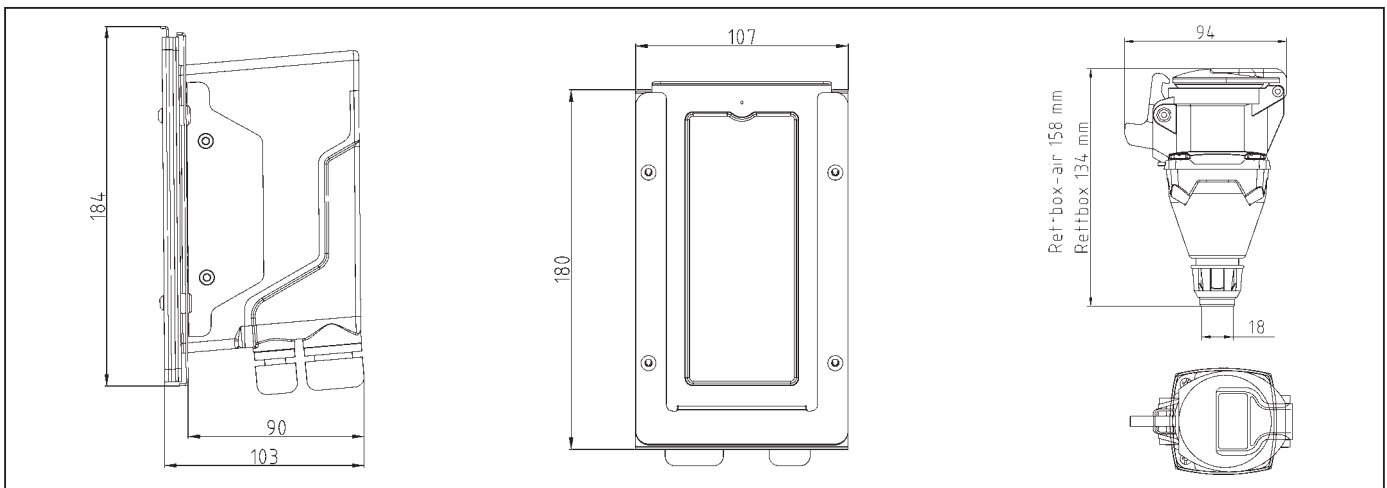

Installation dimensions (cut-out in vehicle): 83 x 163 x 94 mm (W x H x D)

Your dealer:



ISV is a member of the international Butt-contact
 Electrical Connectors Manufacturers'
 Association BECMA

— We will be pleased to send you the specification
 texts for tenders on request —
 See our main catalogue for further plugs and sockets.